



USES AND
RACOMMENDS



www.tmracing.it

TM Racing SpA - Via Fano, 6
61122 Pesaro - ITALY
Phone: +39 0721 25113

2T250MX23-M

MOTORE
ENGINE

25/07/2023



INFORMAZIONI GENERALI

Il presente catalogo serve per richiedere con esattezza le parti di ricambio.

Nelle ordinazioni indicare:

1) Il numero di matricola del Telaio che è stampigliato sul lato destro del canotto di sterzo. Nei modelli EN, SMR, SMR il numero di matricola è riportato anche su una targhetta posta sul lato sinistro (Vedi foto).

2) il numero di serie del Motore. E' posto sulla sinistra del motore tra la leva cambio e i coperchio accensione (Vedi foto).

3) Il codice dei particolari seguito dalla descrizione.

4) Il colore per i pezzi verniciati o comunque colorati.

Le indicazioni destra e sinistra si riferiscono ai lati del veicolo rispetto al senso di marcia.

Foto e disegni sono solo a scopo informativo e potrebbero non corrispondere esattamente alle caratteristiche dei prodotti.

GENERAL INFORMATION

The present spare parts catalogue enables one to order exactly the right spare part.

When ordering specify:

1) The frame serial number. It is embossed on the right side of the steering metal tube. In the EN, SMR and SMR models, the serial number is also stated on a plate positioned on the left hand side (See photo).

2) The engine serial numer. It is located on the left side of the engine between the gear lever and the ignition cover (See photo).

3) The part's code number followed but its description.

4) Indicate colour for painted or colored parts.

References to right and left apply to the vehicle in terms of its direction of movement.

Photos and drawings are for informational purposes only and may not exactly match the characteristics of the products.

NOTE – LEGENDA

MY

NOVITA' INTRODOTTA DIFFERENTE O NON PRESENTE NEL MODELLO DELL'ANNO PRECEDENTE

PART DIFFERENT OR NOT PRESENT IN THE REVIOUS YEAR MODEL

5M

MOTORE CON CAMBIO A 5 MARCE
ENGINE WITH 5 GEARS SPEED

6M

MOTORE CON CAMBIO A 6 MARCE
ENGINE WITH 6 GEARS SPEED

KS

MOTORE CON SOLO KICK STARTER
ENGINE WITH KICK STARTER ONLY

ES

MOTORE CON AVVIAMENTO ELETTRICO
ENGINE WITH ELECTRIC STARTER

X

RICAMBIO NON DISPONIBILE ALLA VENDITA
PART CAN NOT BE SOLD SEPARATELY



Le illustrazioni riportate in questo manuale sono fornite solo come riferimento e possono variare dal prodotto effettivo,

Dati indicativi soggetti a modifiche senza impegno di preavviso.

The illustrations in this manual are for reference only and may vary from the actual product.

All data are subject to modification without prior notice.



2T250MX23-M
MOTORE - ENGINE

SOMMARIO
TABLE OF CONTENTS

| | |
|--|----|
| CILINDRO - CYLINDER..... | 4 |
| MOTORINO VALVOLA - ELECTRIC VALVE SYSTEM..... | 7 |
| ALBERO MOTORE - PISTONE - CRANKSHAFT - PISTON..... | 9 |
| CARTER FRIZIONE - CLUTCH CASE..... | 11 |
| FRIZIONE 5M..... | 13 |
| BASAMENTO E CONTRALBERO..... | 16 |
| FORCHETTE CAMBIO 5M..... | 19 |
| CAMBIO 5M..... | 22 |
| MESSA IN MOTO - KICK STARTER..... | 25 |
| ACCENSIONE - IGNITION..... | 27 |

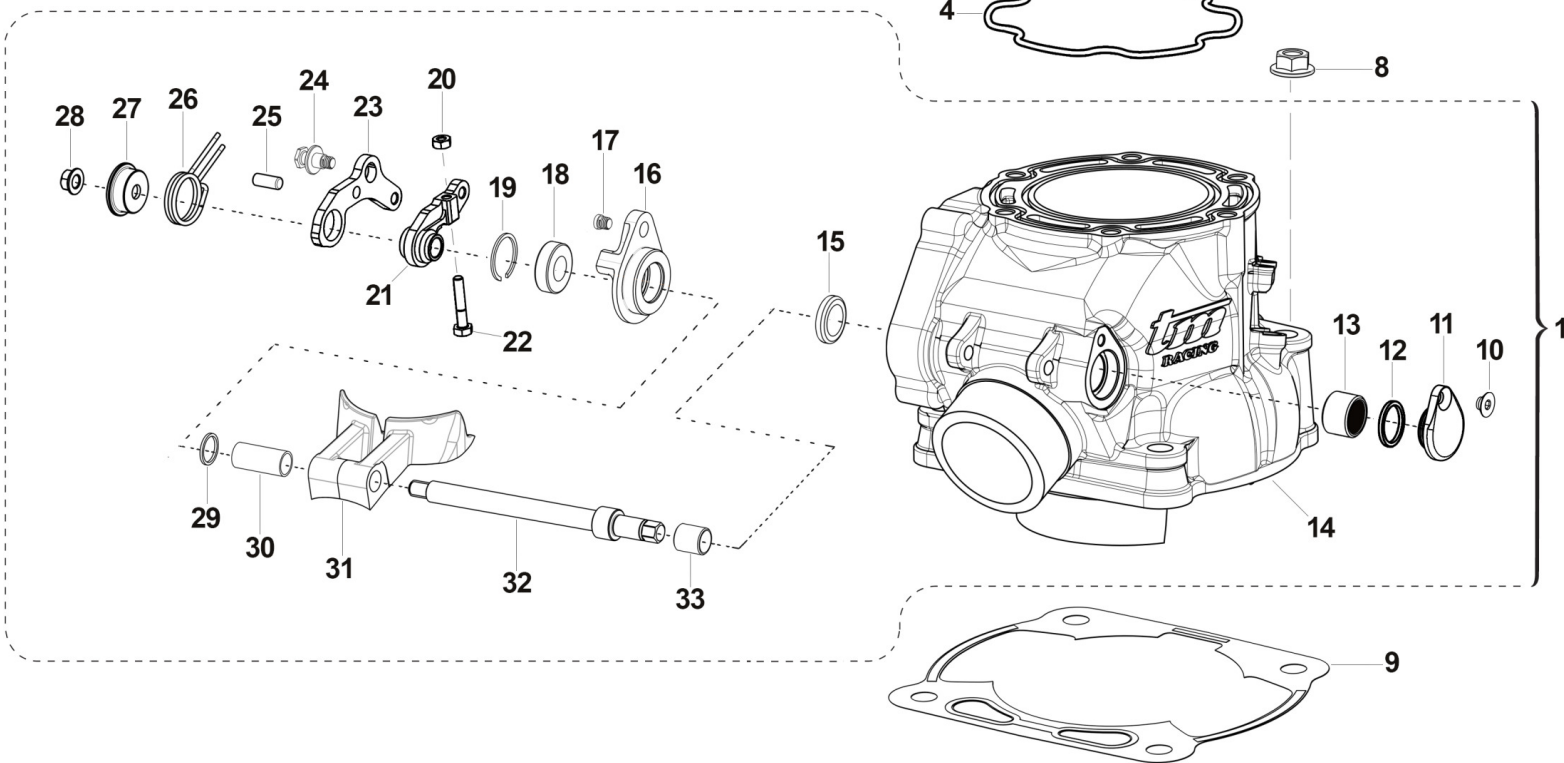
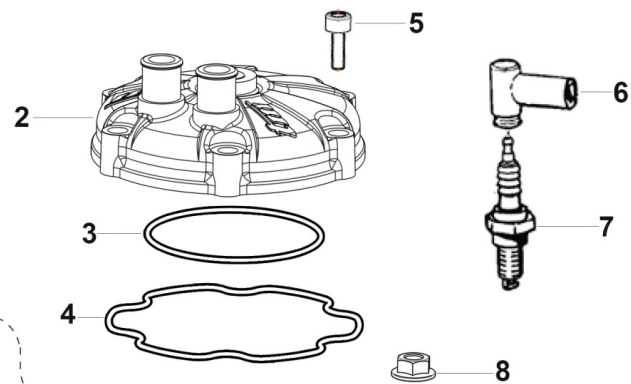
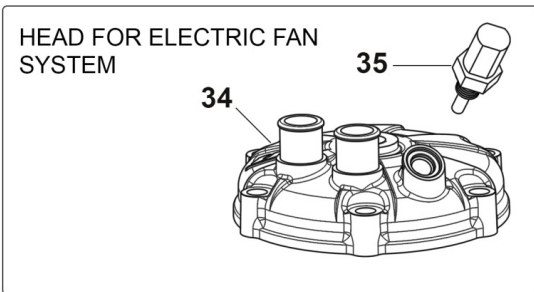



2T250MX23-M
MOTORE - ENGINE

CILINDRO
CYLINDER

1

| Pos. | Codice | Q.tà | Note | Descrizione | Description |
|------|----------|------|------|--|---|
| 1 | 01270 | 1 | | CILINDRO 250 MX/E 2T (CARB 18/23) (Fi 22/23) CPL | CYLINDER 250 MX/E T.S. (CARB) M.19-> ASSY |
| 2 | 02256.19 | 1 | | TESTA 250 2T ES (CARB.) MY 2019 | HEAD 250 T.S. (CARB) M.19-> |
| 3 | 12250 | 1 | | O RING TESTA PICCOLO 250 | O-RING, HEAD 250cc LITTLE |
| 4 | 12263 | 1 | | O RING 250/300 SPECIALE TESTA M.15-> | O-RING 250/300 HEAD BIG M.15 |
| 5 | 49503 | 8 | | VITE TCEI 8X35 UNI 5931-912 Brun | BOLT TCEI 8X35 |
| 6 | 21017 | 1 | | PIPETTA CANDELA NGK LB05EMH | CAP, NGK SPARK PLUG LB05EMH |
| 7 | 06036 | 1 | | CANDELA 250/300 2T M19-> NGK BKR8EIX | SPARK-PLUG 250/300 2S MY19-> BKR8EIX |
| 8 | F49874 | 4 | | DADO M 10 X 1,25 CH 12 FLANGIATO | NUT FLANGED M 10x1,25 T.12mm |
| 9 | 05280.20 | 1 | | GUARN. B/CIL 250 sp. 0.2 M.15-> | GASKET, CYL 250 M.15 0,2 |
| 9 | 05280.30 | 1 | | GUARN. B/CIL 250 sp. 0.3 M.15-> | GASKET, CYL 250 M.15 0,3 |
| 9 | 05280.40 | 1 | | GUARN. B/CIL 250 sp. 0.4 M.15-> | GASKET, CYL 250 M.15 0,4 |
| 9 | 05280.50 | 1 | | GUARN. B/CIL 250 sp. 0.5 M.15-> | GASKET, CYL 250 M.15 0,5 |
| 10 | 49399 | 1 | | VITE TSEI 5X12 | BOLT TSEI 5x12 |
| 11 | 30217 | 1 | | TAPPO SX ALB.COM.VALV.PAL.125 | SIDE COVER |
| 12 | F12308 | 1 | | O RING 17,5 - 1,5 | O-RING 17,5 - 1,5 |
| 13 | 19044 | 1 | | GABBIA A RULLI FRENO POST. | NEEDLE BUSH REAR BRAKE PEDAL |
| 14 | 01269 | 1 | | CILINDRO 250 MX/E 2T (CARB) NUDO 19-> | CYLINDER 250 MX/E (CARB) MY19 |
| 15 | 04115 | 1 | | PARAOLIO G 12X18X3 | OIL SEAL 12x18x3 |
| 16 | 26258 | 1 | | FLANGIA PORTACUSC.ALB.VALV.250/300 IE | FLANGE, BEARING HOLDER |
| 17 | 49757 | 1 | | VITE TBCE 5 X 12 | BOLT TBCE 5X12 |
| 18 | 03156 | 1 | | CUSCINETTO V.SC.C.12 698LLU/5K | BUSH, EXHAUST VALVE 698LLU |
| 19 | 49220 | 1 | | SEEGER INT.19 | SEEGER I 19 |
| 20 | 49630 | 1 | | DADO M 4 (BASSO) | NUT 4mm, LOW |
| 21 | 28262 | 1 | | LEVA INTERNA COMANDO VALVOLE EES-2 250/300 2019 | LEVER, INTERNAL, 250/300 |
| 22 | 49738 | 1 | | VITE TE 4X20 | BOLT TE 4X20 |
| 23 | 28263 | 1 | | LEVA ESTERNA COMANDO VALVOLE EES-2 | LEVER, EXTERNAL, VALVE |
| 24 | 26168 | 1 | | PERNO MOLLA EES-2 16066 | PIN, SPRING |
| 25 | F19536 | 1 | | RULLO D. 5 X 12 M6 DIN 6325 | PIN 5X12 |



2T250MX23-M
MOTORE - ENGINE

CILINDRO
CYLINDER

1

| Pos. | Codice | Q.tà | Note | Descrizione | Description |
|------|----------|------|------|--|---|
| 26 | 16066 | 1 | | MOLLA EES-2 | SPRING EES-2 |
| 27 | 26167 | 1 | | PIATTELLO GUIDA MOLLA EES-2 16066 | COLLAR, SPRING |
| 28 | 49676 | 1 | | DADO M 6X1 FLANG. AUTOBL.ACC. | NUT, FLANGED M6 X 1 S.B. |
| 29 | 26130.12 | 1 | | SPESS. REG. CIL.125 2012 1.2 | SPACER CYL. 125 ->12 1.2 |
| 29 | 26130.13 | 1 | | SPESS. REG. CIL.125 2012 1.3 | SPACER CYL. 125 ->12 1.3 |
| 29 | 26130.14 | 1 | | SPESS. REG. CIL.125 2012 1.4 | SPACER CYL. 125 ->12 1.4 |
| 29 | 26130.15 | 1 | | SPESS. REG. CIL.125 2012 1.5 | SPACER CYL. 125 ->12 1.5 |
| 29 | 26130.16 | 1 | | SPESS. REG. CIL.125 2012 1.6 | SPACER CYL. 125 ->12 1.6 |
| 29 | 26130.17 | 1 | | SPESS. REG. CIL.125 2012 1.7 | SPACER CYL. 125 ->12 1.7 |
| 29 | 26130.18 | 1 | | SPESS. REG. CIL.125 2012 1.8 | SPACER CYL. 125 ->12 1.8 |
| 29 | 26130.19 | 1 | | SPESS. REG. CIL.125 2012 1.9 | SPACER CYL. 125 ->12 1.9 |
| 30 | 26147 | 1 | | BOCCOLA DIST. CIL. 250/300 2015 + 125 2020 | BUSH |
| 31 | 22261.19 | 1 | | VALVOLE SCARICO 250 2T ES MY 2019 | VALVES, EXHUAST 250 2S MY19 |
| 32 | 28256 | 1 | | ALBERO COMANDO PALETTE 250 | SHAFT BOOSTER 250/300 |
| 33 | 19061 | 1 | | BOCCOLA IR 8X12X12.5 | BUSH, IR 1X12X12,5 |
| 34 | 02257 | 1 | | TESTA 250 2T IE | HEAD 250 2S FI |
| 35 | 08014 | 1 | | SENSORE TEMP. ACQUA TESTA 2T Fi MY19 | SENSOR, WATER TEMPERATURE HEAD 250/300 2T Fi 19-> |

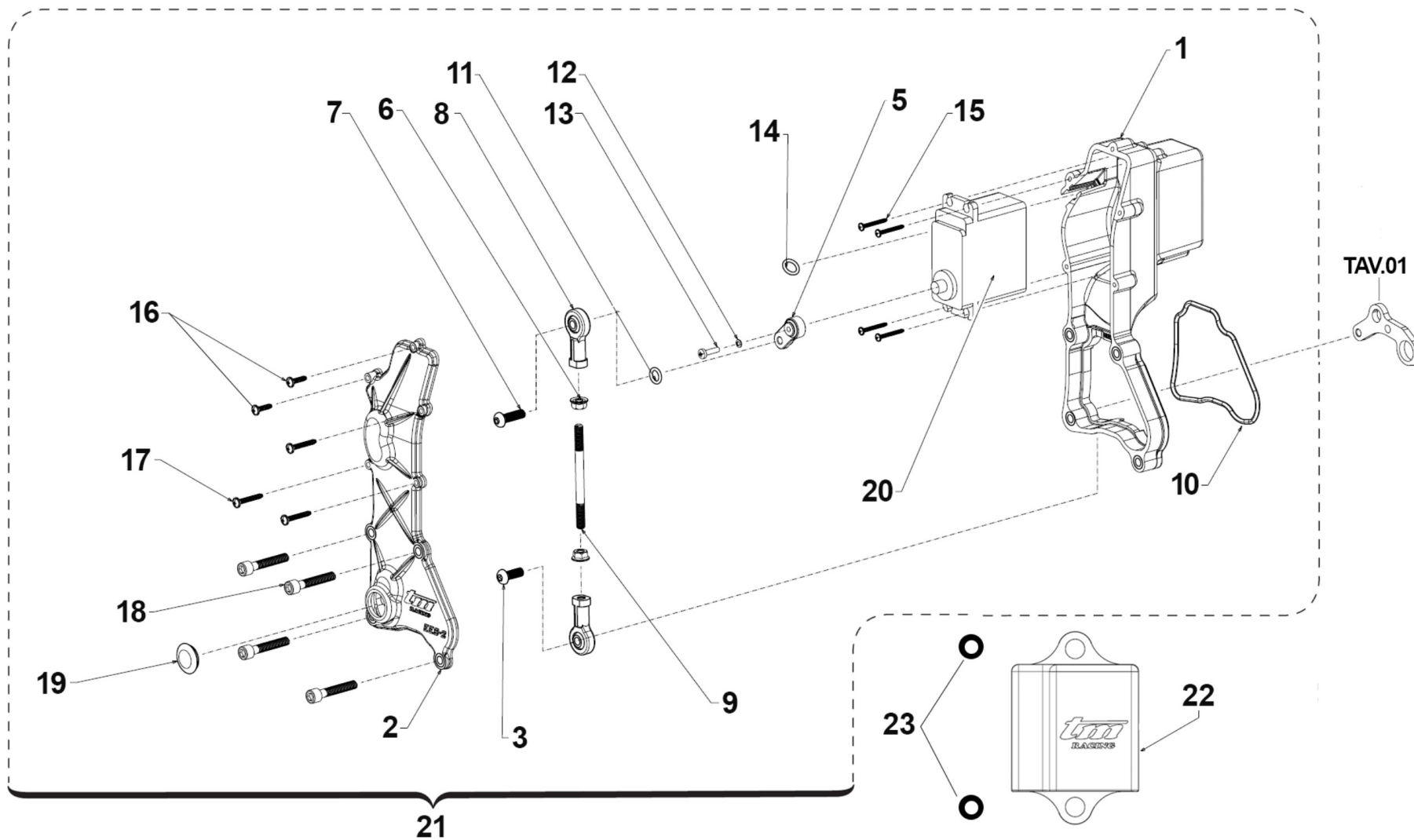



2T250MX23-M
MOTORE - ENGINE

MOTORINO VALVOLA
ELECTRIC VALVE SYSTEM

2

| Pos. | Codice | Q.tà | Note | Descrizione | Description |
|------|----------|------|------|--|--|
| 1 | 30285 | 1 | | CARTER EES-2 250/300 2T IE | BOX, PLASTIC |
| 2 | 30286 | 1 | | COPERCHIO CARTER EES-2 250/300 2T IE | COVER, PLASTIC |
| 3 | 49890 | 1 | | VITE TBCEI 5 x 14 UNI 7380 10.9 | SCREW TBCE 5X14 |
| 5 | 28266.0 | 1 | | LEVA SERVOMOTORE EES-2 DENTATURA 0 | LEVER |
| 5 | 28266.1 | 1 | | LEVA SERVOMOTORE EES-2 DENTATURA 1 | LEVER |
| 6 | 49632 | 2 | | DADO M 5 x 0,8 ZB | NUT 5mm |
| 7 | 49929 | 1 | | VITE 10.9 TBCEI 5 x 18 UNI 7380 | BOLT |
| 8 | 72251 | 2 | | SNODO MECCANISCO VALVOLA EES-2 125/250/300 | JOINT EXHAUST VALVE EES-2 250/300 |
| 9 | 28264 | 1 | | ASTINA COLLEGAMENTO UNIBALL EES-2 250/300 2019 | ROD UNIBALL EES-2 250/300 2S MY19-> |
| 10 | 12042 | 1 | | O RING COP. VALVOLA EES-2 | O-RING |
| 11 | F12301 | 1 | | O RING 106 4T PIOGGIA CAMBIO | O-RING, 106 GEAR F.S. |
| 12 | 49124 | 1 | | RONDELLA SCHNORR ZIG. 2.5 | |
| 13 | 49881 | 1 | | VITE T.C. 2,5X12 | |
| 14 | F12321 | 1 | | O RING BOCCOLA CENTR. CILINDRO | O-RING |
| 15 | 49973 | 4 | | VITE STS-Plus KN6031 2.2X20 PLASTICA | BOLT |
| 16 | 49984 | 2 | | VITE TCBL 3.0 X 12 FL. PLASTICA | BOLT |
| 17 | 49919 | 3 | | VITE TCBL 3.0X 20 FL. X PLAST. | BOLT |
| 18 | 49478 | 4 | | VITE TCEI 5X30 UNI 5931 | BOLT TCEI 5X30 |
| 19 | 21009 | 1 | | TAPPO GOMMA COPERCHIO VALV.SC. | RUBBER, COVER |
| 20 | 22500 | 1 | | SERVOMOTORE VALV.SCARICO HITEC | EL. ENGINE EXHAUST VALVE HITEC |
| 21 | 22503.19 | 1 | | SERVOMOTORE V/SC. CPL 250/300 ES MY 2019 | EL. ENGINE EXHAUST, ASSY |
| 22 | 08023 | 1 | | CENTRALINA COMANDO VALV.SC. 250/300 EES-2 125 Fi | ECU EXHAUST VALVE CONTROL 250/300 2S EES-2 |
| 23 | F21444 | 2 | | GOMMINO CENTRALINA COMANDO VALV. MY 2019 | RUBBER ECU HOLDER EXHAUST VALVE M.19-> |

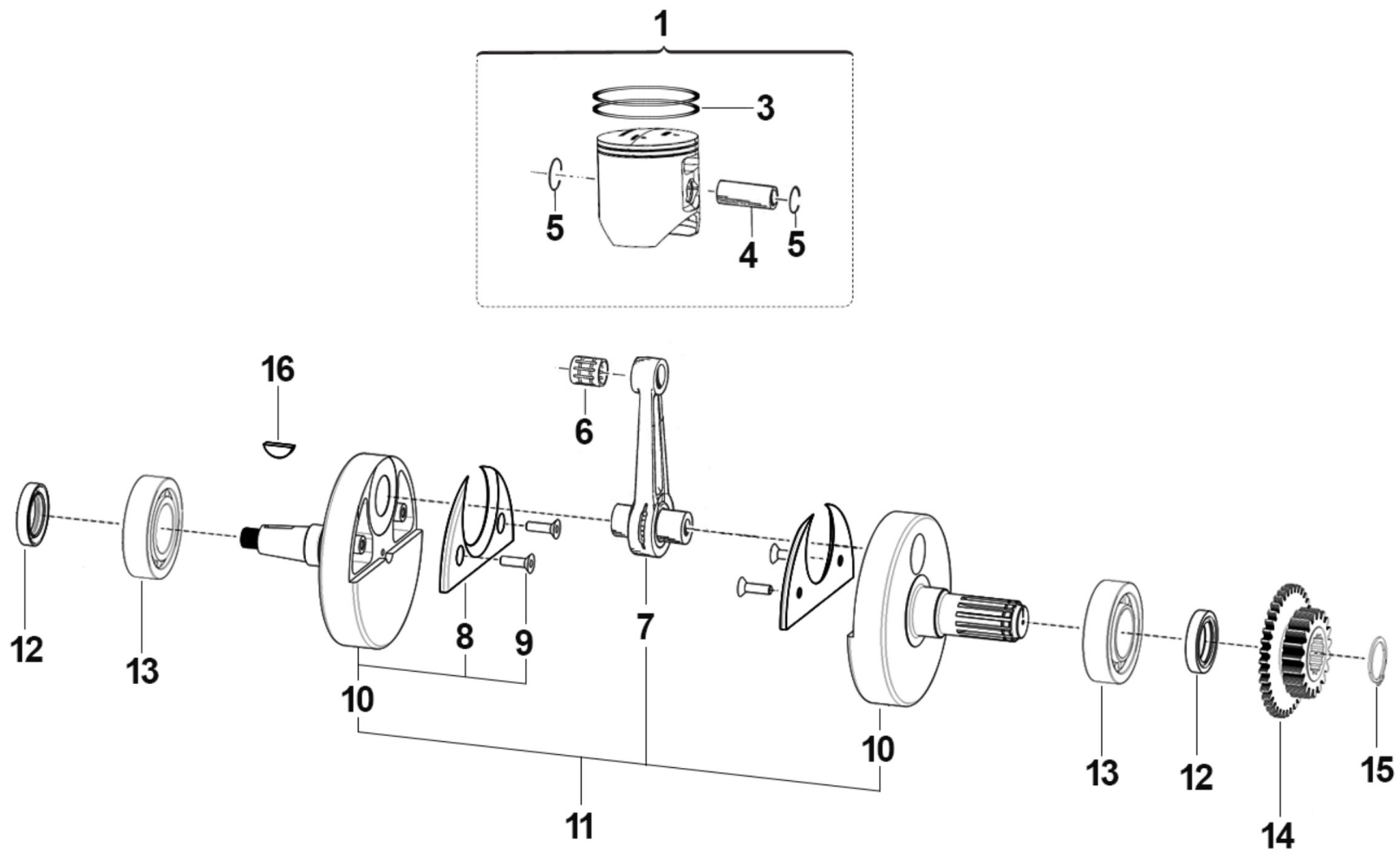



2T250MX23-M
MOTORE - ENGINE

ALBERO MOTORE - PISTONE
CRANKSHAFT - PISTON

3

| Pos. | Codice | Q.tà | Note | Descrizione | Description |
|------|----------|------|------|--|---------------------------------|
| 1 | 10513.33 | 1 | | PISTONE 66,33 2F 250 CPL M. 19-> | PISTON 66,33 2S 250 ASSY MY19-> |
| 1 | 10513.34 | 1 | | PISTONE 66,34 2F 250 CPL M.19-> | PISTON 66,34 2 RINGS |
| 1 | 10513.35 | 1 | | PISTONE 66,35 2F 250 CPL M.19-> | PISTON 66,35 2 RINGS |
| 1 | 10513.36 | 1 | | PISTONE 66,36 2F 250 CPL M.19-> | PISTON 66,36 2 RINGS |
| 3 | 11251 | 2 | | SEGMENTO 250 CC | PISTON RING 250cc |
| 4 | 09250 | 1 | | SPINOTTO PISTONE 250/300cc | PIN, PISTON 250/300cc |
| 5 | 09251 | 2 | | ANELLINO FERMA SPINOT.250/300 | CLIP, PISTON PIN 250/300 |
| 6 | 19250 | 1 | | GABBIA SPINOTTO 250/300 cc | TOP END BUSH 250/300cc |
| 7 | 18246 | 1 | | BIELLA 250/300 M.05/-> P. CPL | CONROD KIT, 250/300 M.05/-> |
| 8 | 18270 | 2 | | GUANCETTA SEMIALB. 250/300Fi | STUFFERS, CRANKSHAFT |
| 9 | 49404 | 4 | | VITE TSEI 6X16 | BOLT TSEI 6x16 |
| 10 | 18268 | 1 | | COPPIA SEMIALBERI 250/300 EV18 | CRANK LH + RH |
| 11 | 18266.19 | 1 | | ALBERO MOTORE 250/300 2T ES MY 2019 | CRANKSHAFT 250/300 2S FI MY.19 |
| 12 | 04112.1 | 2 | | PARAOLIO 25X38X7 FKM 250/300 | |
| 13 | 03051 | 2 | | CUSCINETTO 6206 - Z/C4 | |
| 14 | 40243 | 1 | | PIGNONE C.PRIM.250/300 Z19 M18 PER CONTRALBERO | GEAR, PRIMARY 19 T |
| 15 | 49252 | 1 | | SEEGER PIGNONE CATENA 250 E 25 | CIRCLIP D.25 FRONT SPROKET 250 |
| 16 | 49012 | 1 | | CHIAVETTA PIGNONE COPPIA 250 | WOODRUFF KEY, 250/300 19x7,5x5 |

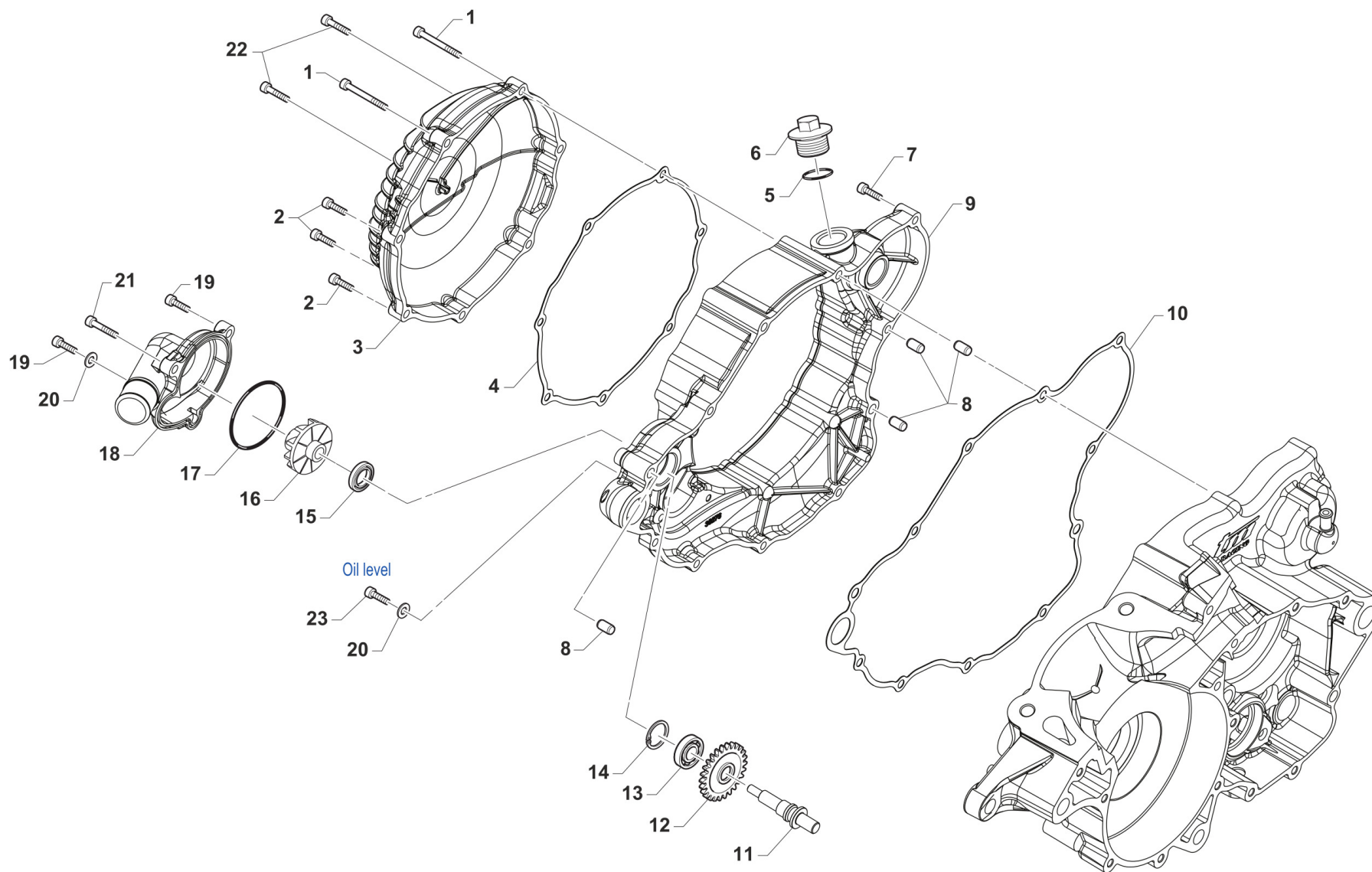

TM25020-004



2T250MX23-M
MOTORE - ENGINE

CARTER FRIZIONE
CLUTCH CASE

4

| Pos. | Codice | Q.tà | Note | Descrizione | Description |
|------|----------|------|------|--|--|
| 1 | 49986 | 2 | | VITE TCEI 5X75 | BOLT TCEI 5 X 75 |
| 2 | 49477 | 3 | | VITE TCEI 5X25 UNI 5931-912 | BOLT TCEI 5X25 |
| 3 | 30277 | 1 | | COPERCHIO FRIZIONE 250/300 2T MY'19 | COVER, CLUTCH 250/300 TS M.19-> |
| 4 | 05284 | 1 | | GUARN. COP. FRIZIONE 250/300 2T ES M19-> | GASKET, CLUTCH COVER 250/300 2S ES MY 19 |
| 5 | F49920 | 1 | | RONDELLA ALL 20.4X26X1.5 | WASHER 20,4X26X1,5 ALUM. |
| 6 | F49925 | 1 | | TAPPO CARICO OLIO M20X1.5 | OIL PLUG M20X1,5 |
| 7 | 49477 | 9 | | VITE TCEI 5X25 UNI 5931-912 | BOLT TCEI 5X25 |
| 8 | 26041 | 2 | | GRANO CENTRAGGIO D.7X8 F.5,2 | DOWEL PIN 7 x 8 Hole 5,2 |
| 9 | 30288 | 1 | | CARTER FRIZIONE 250/300 2020 | COVER, INTERNAL, CLUTCH |
| 10 | 05285 | 1 | | GUARN. CARTER INT. FRIZ. 250/300 2T ES MY 2020 | GASKET, INT. CLUTCH COVER 250/300 2T ES M 20-> |
| 11 | 28068 | 1 | | ALBERINO POMPA ACQUA 250 SC. | SHAFT WATER PUMP 250 |
| 12 | 40074 | 1 | | INGR COMANDO POMPA H2O 250 ES MY 2019 | GEAR, WATER PUMP |
| 13 | 03014 | 1 | | CUSCINETTO 608 ZC3 POMPA SCHER | BUSH, WATER PUMP 608 Z C3 |
| 14 | 49215 | 1 | | SEEGER I22 POMPA ACQUA | CIRCLIP D.22 WATER PUMP |
| 15 | F04363 | 1 | | PARAOLIO 8X22X5 250/09-> | OIL SEAL 8x22x5 (250F/09) |
| 16 | F28679 | 1 | | GIRANTE POMPA ACQUA 250N | IMPELLER, H2O PUMP 250Fi |
| 17 | 12028 | 1 | | OR COP. POMPA H2O 2T 250/300 M.18-> | O-RING WATER PUMP COVER 2S 250/300 MY.18-> |
| 18 | 30275.20 | 1 | | COPERCHIO POMPA ACQUA 250/300 2T Fi MY 2020 | COVER, WATER PUMP 250/300 2S ES MY 2019 |
| 19 | 49476 | 2 | | VITE TCEI 5X20 UNI 5931 | BOLT TCEI 5X20 |
| 20 | 49119 | 2 | | RONDELLA 5 x 9 x 1,5 ALLUMINIO | WASHER, 5 x 9 x 1.5 ALLUMINIUM |
| 21 | 49570 | 1 | | VITE TCEI 5X50 UNI 5931 | SCREW TCEI 5X50 |
| 22 | 49478 | 2 | | VITE TCEI 5X30 UNI 5931 | BOLT TCEI 5X30 |
| 23 | 49472 | 1 | | VITE TCEI 5X12 UNI 5931-912 Brun | BOLT TCEI 5X12 |

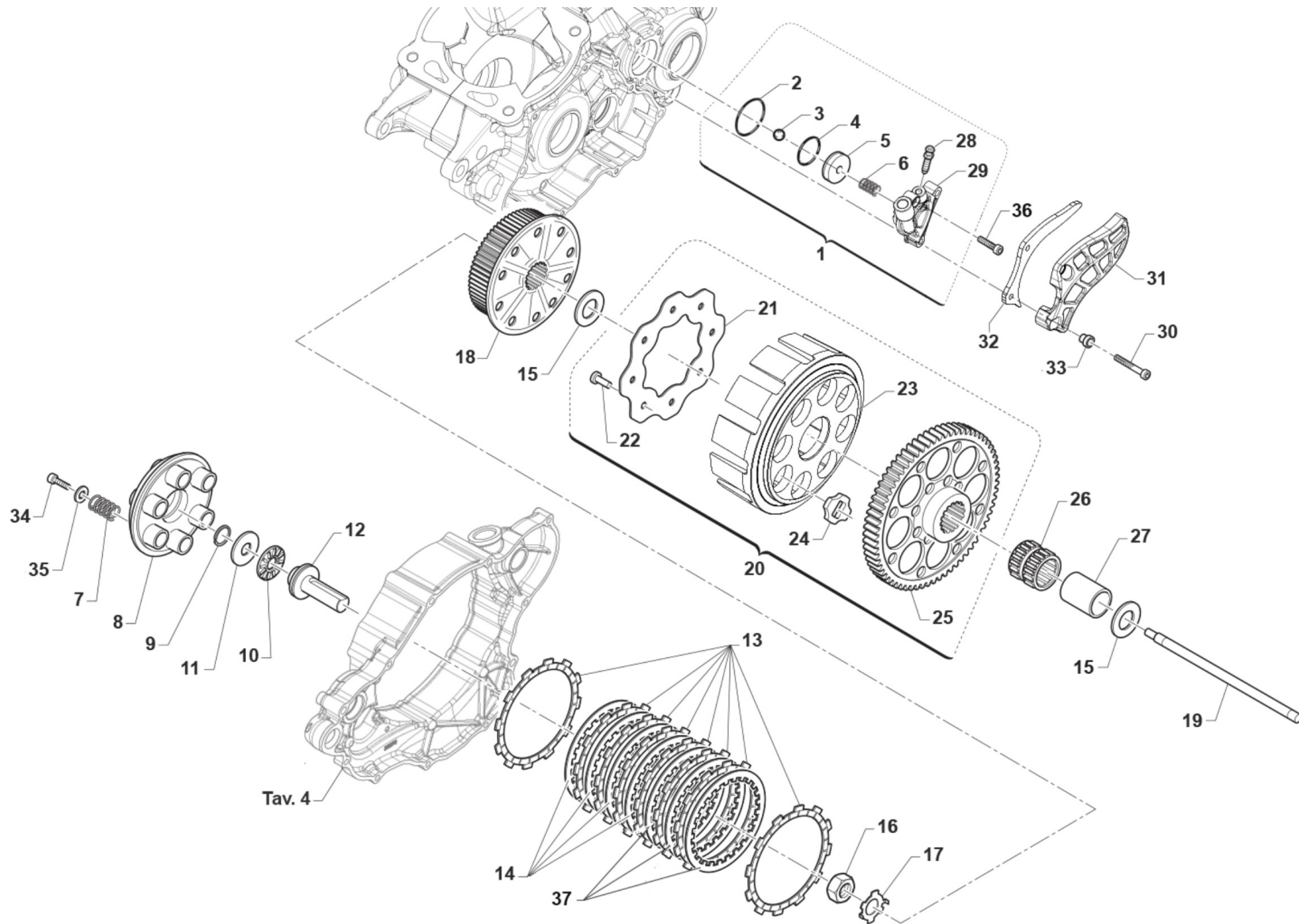



2T250MX23-M
MOTORE - ENGINE

FRIZIONE 5M

5

| Pos. | Codice | Q.tà | Note | Descrizione | Description |
|------|----------|------|------|--|--|
| 1 | 30265.19 | 1 | | COP. FRIZ/IDR 2T 250/300 ES MY 2019 CPL | COVER IDR.CLUTCH 250/300 T.S. ES MY19-> ASSY |
| 2 | 12091 | 1 | | O RING CORPO CARTUCCIA FR.COMP | O-RING |
| 3 | F19517 | 1 | | SFERA X PIST.FRIZ.IDRAUL.250N | BALL IDR. CLUTCH PISTON 250N |
| 4 | 12268 | 1 | | O RING PISTONE FRIZ.250/300 2T 19 VERDE | O-RING CLUTCH PISTON 250/300 TS M.19-> |
| 5 | F35559 | 1 | | PISTONCINO CIL.FRIZ.D.27XRING | PISTON |
| 6 | F16470 | 1 | | MOLLA CONTR. PIST/FRI 450Fi'15 | |
| 7 | F16453 | 6 | | MOLLA FRIZIONE 2/4T 250/450 | SPRING, CLUTCH 2/4T 250/450 |
| 8 | 25253 | 1 | | PIATTO SPING. 250/300 + 4T | PLATE, CLUTCH PRESSURE |
| 9 | 09006 | 1 | | ANELLINO FERMA SPINOTTO 80/85/100 | CLIP, PISTON PIN 80/85/100cc |
| 10 | 19022 | 1 | | GABBIA A RULLI RAD. AXK 1528 | BUSH CAGE AXK 1528, RADIAL |
| 11 | 19023 | 1 | | RONDELLA GABBIA RULLI AS 1528 | WASHER, NEEDLE CAGE AS 1528 |
| 12 | F35582 | 1 | | FUNGO FRIZIONE IDRAULICA 2015 | PIECE, CLUTCH LIFTER |
| 13 | F35589 | 8 | | DISCO FRIZIONE 141-E7G02-00 2T/4T FCC | CLUTCH FRICT. PLATE 141-E7G02-00 2S/4S FCC |
| 14 | 35254 | 4 | | DISCO FRIZ. ACC. 1,5 mm 250+4T | CLUTCH PLATE, STEEL 1,5mm94/98 |
| 15 | 48250 | 2 | | SPESSORE COPPIA PRIMARIA 250 | SPACER, PRIMARY GEAR 250cc |
| 16 | 49060 | 1 | | DADO TAMBUR.FRIZ. ALB.PRIM. 250/300 M18X1.5 | NUT, CLUTCH CENTER 250cc |
| 17 | 35050 | 1 | | RONDELLA X FRIZ. 250/300/4T | CLUCTH WASHER 250/300/F |
| 18 | 25255 | 1 | | TAMBURELLO FRIZIONE 250/300 2T ES MY 2019 | CENTRAL HUB |
| 19 | 35503 | 1 | | ASTINA FRIZIONE IDRAULICA 250/300 IE M19 | ROD, CLUTCH |
| 20 | 40245.19 | 1 | | COPPIA PRIM. 250/300 2T ES z57 CPL MY 2019 | PRIMARY GEAR ASSY |
| 21 | 35262.1 | 1 | | DISCO BATTUTA GOMMINI FRIZ. 2T/4T F.7 MMPER VITI 49727 | |
| 22 | 49727 | 8 | | VITE PARASTRAPPI K9 M7X1X12.5 | SCREW, M7X1X12,5 K9 ENGINE |
| 23 | 25254 | 1 | | CAMPANA FRIZIONE 250 / 300 M.19-> | CLUTCH BASKET 250/300 MY 19-> |
| 24 | 21005 | 8 | | GOMMINO PARASTRAPPI FRIZIONE | RUBBER, CLUTCH BASKET |
| 25 | 40242 | 1 | | CORONA COPPIA PRIM. 250/300 2T ES Z57 MY 2019 | GEAR, PRIMARY 57 T |
| 26 | F19510 | 1 | | GABBIA A RULLINI K 27X32X23.8 | NEEDLE CAGE 27 x 32 x 23.8 |
| 27 | F26422 | 1 | | BOCCOLA INGR.TRASM.PRIM. 250N | BUSH, PRIMARY GEAR 250Fi |



2T250MX23-M
MOTORE - ENGINE

FRIZIONE 5M

5

| Pos. | Codice | Q.tà | Note | Descrizione | Description |
|------|--------|------|------|--|-------------------------------------|
| 28 | 35264 | 1 | | VITE SPURGO OLIO FRIZ.IDR.6X1 | SCREW AIR BLED HYDRAUL.CLUTCH |
| 29 | 30269 | 1 | | COP. FRIZ/IDR NUDO 250/300 M19 | COVER IDR. CLUTCH 2S 250/300 MY19-> |
| 30 | 49535 | 2 | | VITE TCEI 5X35 UNI 5931-912 Brun | BOLT TCEI 5X35 |
| 31 | 40075 | 1 | | PROTEZIONE PIGNONE 250/300 IE | PROTECTION, PLASTIC |
| 32 | 40042 | 1 | | PROTEZIONE PIGNONE ERGAL 250/300 2T ES MY 2019 | PROTECTION, ERGAL |
| 33 | 26211 | 2 | | BOCCOLA PROT. PIGNONE 250 F.5 | COLLAR, SPROCKET 250cc H.5 |
| 34 | 49484 | 6 | | VITE TCEI 6X20 | BOLT TCEI 6X20 |
| 35 | 49604 | 6 | | RONDELLA 6 X18 X 1,6 | WASHER 6x18 |
| 36 | 49474 | 1 | | VITE TCEI 5X16 UNI 5931 | BOLT TCEI 5X16 |
| 37 | 35250 | 3 | | DISCO FRIZ. ACC. 1,8 mm 250+4T | CLUTCH PLATE, STEEL 1,8mm 250 |

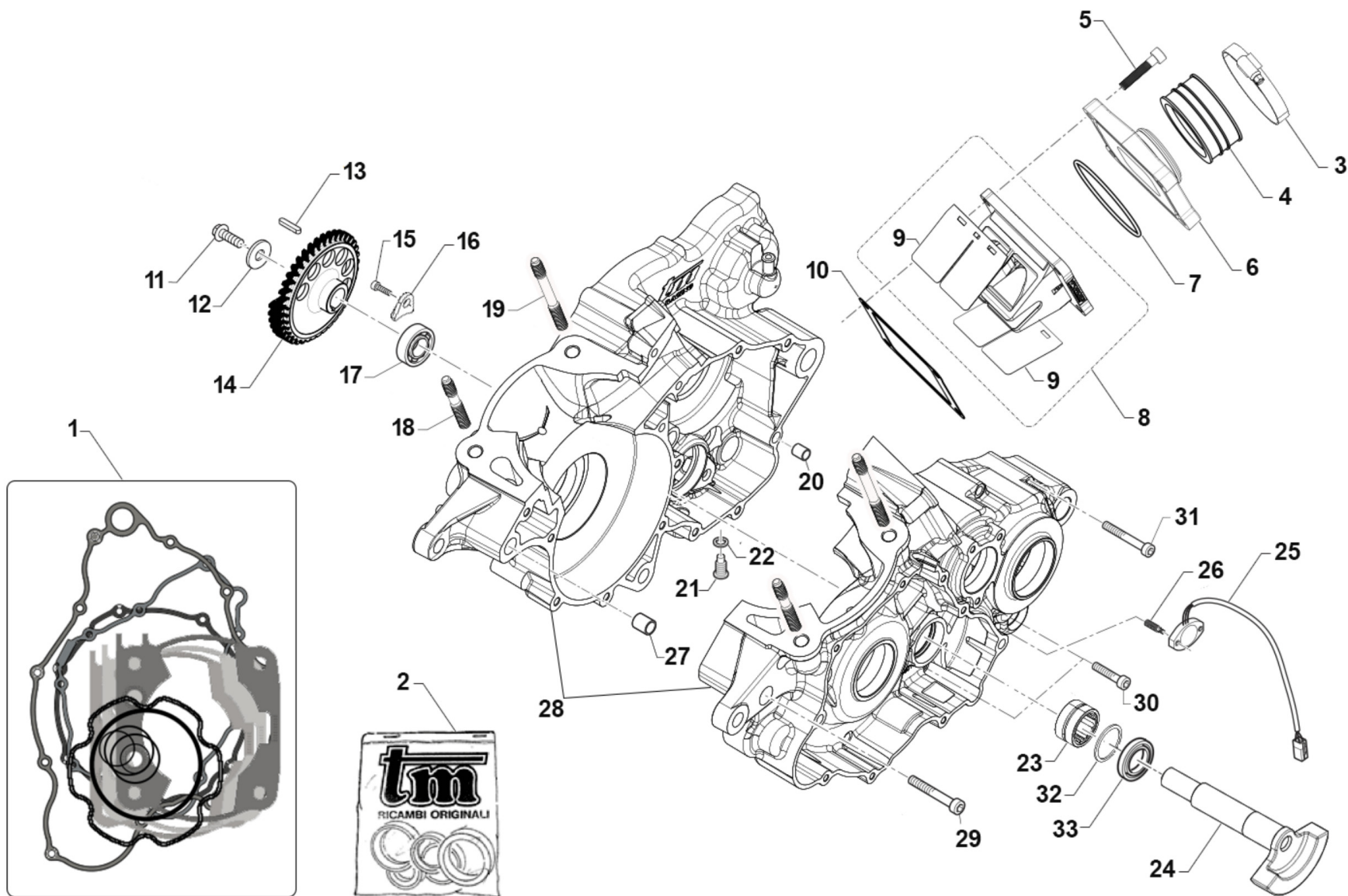



2T250MX23-M
MOTORE - ENGINE

BASAMENTO E CONTRALBERO

| Pos. | Codice | Q.tà | Note | Descrizione | Description |
|------|----------|------|------|---|------------------------------------|
| 1 | 05610.20 | 1 | MY20 | KIT GUARNIZIONI + OR 250cc 2T ES MY2020 | GASKETS + OR 250 2S ES MY 2020 |
| 2 | 04029.19 | 1 | | KIT PARAOLI 250/300 2T ES MY 2019 | OIL SEAL KIT 250/300 2T ES MY 2019 |
| 3 | 51054 | 2 | | FASCETTA SM9 D.52 | CLAMP SM9 D.52mm |
| 4 | 13009 | 1 | | MANICOTTO COLLETTORE ASP.97/14 | MANIFOLD RUBBER,INTAKE M.97/14 |
| 5 | 49486 | 4 | | VITE TCEI 6X30 UNI 5931 | BOLT TCEI 6X30 |
| 6 | 30314.14 | 1 | | CONVOGL. P/LAM 250/3 14/-> VF3 | MANIFOLD, INTAKE |
| 7 | 12255 | 1 | | O RING COLLETT.ASP.250/300 14 | O-RING, INLET MANIFOLD 250/300 |
| 8 | 20258 | 1 | | PACCO LAM 250/300 VF3 07/-> | REEDS BOX VF3 250/300 M. 07/-> |
| 9 | 20076 | 1 | | LAMELLE V-FORCE3 250/300 07/-> | REEDS, V-FORCE3 250/300 07/-> |
| 10 | 05268 | 1 | | GUARN. PACCO LAMELLE 250 | GASKET, REED BLOCK 250/300 |
| 11 | 49363 | 1 | | VITE TE F/R 8X16 Ch.10 | BOLT 8X16 T.10mm |
| 12 | 49100 | 1 | | RONDELLA TESTATA 8,5x18x3 ZB | WASHER, HEAD 8x18x3 |
| 13 | 49969 | 1 | | CHIAVETTA CONTRALBERO 250/300 2T A 3X3X12 | WOODRUFF KEY |
| 14 | 40257 | 1 | | INGR. CONTRALBERO 250/300 M18 | GEAR, BALANCE SHAFT |
| 15 | 49962 | 1 | | VITE TCEI 6X12 BASSA / F.GUIDA | BOLT |
| 16 | 26156 | 1 | | PIASTRINO BLOC.CUSC.C.A.125 OK /250/300 | PLATE, BEARING HOLDER 125 OK |
| 17 | 03049 | 1 | | CUSCINETTO CONTRALBERO MOTO 2T | BUSH, COUNTERSHAFT 2S BIKE |
| 18 | 49044 | 2 | | PRIGIONIERO CARTER/CILIND.250/300 ES Ant. | STUD, M10 X 1.25 L.57 |
| 19 | 49045 | 2 | | PRIGIONIERO CARTER/CILIND. 250/300 ES Post. | STUD, M10 X 1.25 L.81,5 |
| 20 | F26304 | 1 | | GRANO RIFERIMENTO 6.5X8X9.5 4T | GRUB SCREW 6.5X8XX9.5 4S |
| 21 | 49301 | 1 | | TAPPO OLIO C/CALAM. 2T | OIL PLUG WITH MAGNET |
| 22 | 49103 | 1 | | RONDELLA 14X20X1,5 ALLUMINIO | WASHER, 14 X 20 X 1.5 ALUMINUM |
| 23 | 19078 | 1 | | ASTUCCIO A RULLI NK 2020 C/ALB. 250/300 2T I. | |
| 24 | 18267 | 1 | | CONTRALBERO 2T 250/300 ES MY 2019 | BALANCE SHAFT |
| 25 | F08459 | 1 | | SENSORE POSIZIONE CAMBIO eM060 CPL G.ANTIORARIO | |
| 26 | 49713 | 2 | | GRANO 6X20 FRIZ. KART-CROSS | GRUB SCREW |
| 27 | F26428 | 1 | | GRANO RIFERIMENTO 12X13 F10.2 | GRUB SCREW 12X13 H.10,2mm |
| 28 | 30280.20 | 1 | MY20 | BASAMENTO MOTORE 250 2T ES MY 2020 | CRANKCASE 250 2S ES MY20 |



2T250MX23-M
MOTORE - ENGINE

BASAMENTO E CONTRALBERO

6

| Pos. | Codice | Q.tà | Note | Descrizione | Description |
|------|--------|------|------|-------------------------|---------------------------|
| 29 | 49508 | 1 | | VITE TCEI 8X60 UNI 5931 | BOLT |
| 30 | 49487 | 3 | | VITE TCEI 6X35 UNI 5931 | BOLT TCEI 6X35 |
| 31 | 49490 | 11 | | VITE TCEI 6X50 UNI 5931 | BOLT TCEI 6X50 |
| 32 | 49274 | 1 | | SEEGER JV 30 | |
| 33 | 04035 | 1 | | PARAOLIO 20x30x7 PTFE | OIL SEAL 20 x 30 x 7 PTFE |

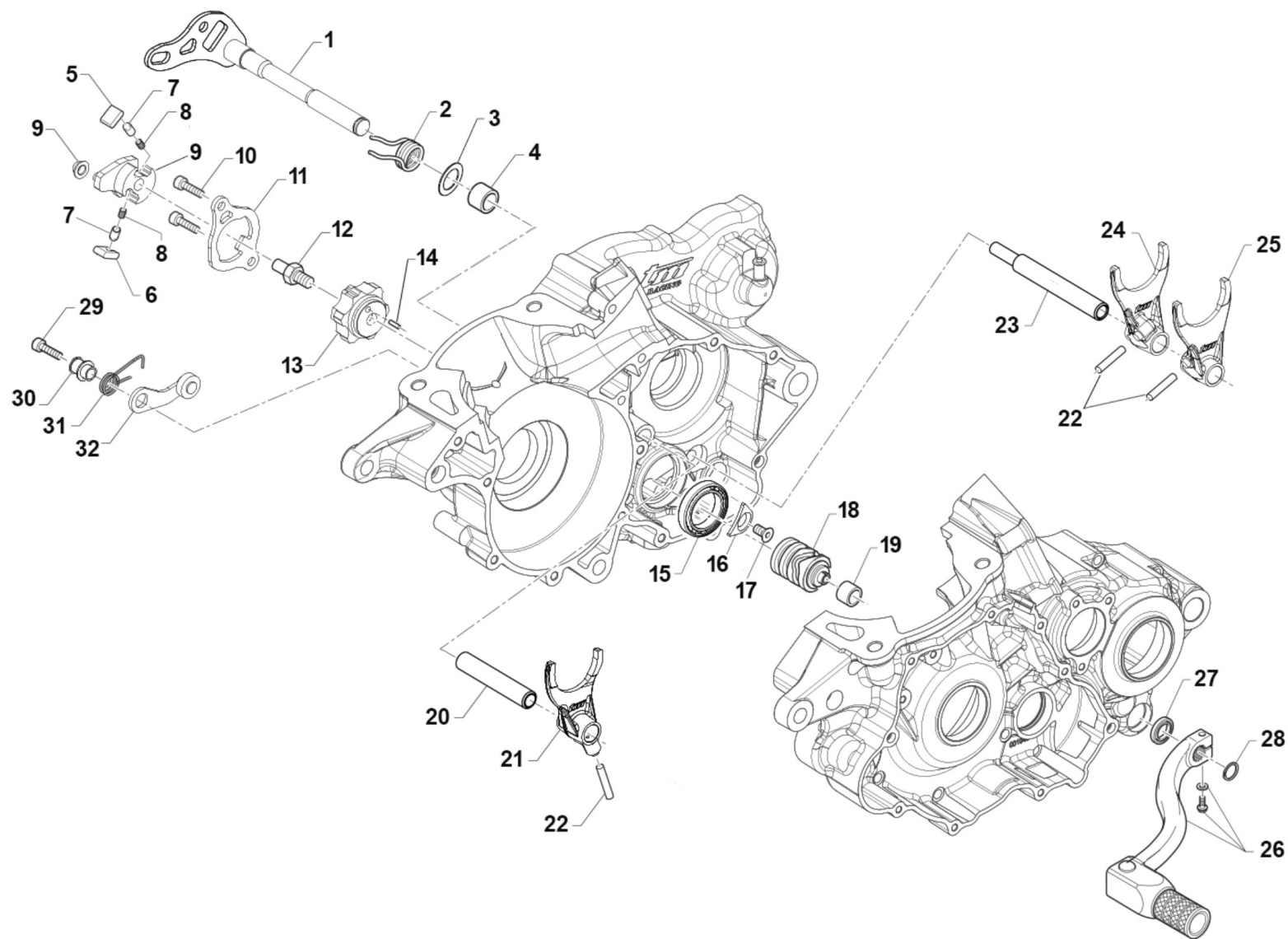



2T250MX23-M
MOTORE - ENGINE

FORCHETTE CAMBIO 5M

7

| Pos. | Codice | Q.tà | Note | Descrizione | Description |
|------|--------|------|------|---|---|
| 1 | 28105 | 1 | | ALBERO COMANDO CAMBIO 250/300 IE CPL | SHAFT, GEARSHIFT 250/300 IE CPL |
| 2 | 16065 | 1 | | MOLLA RITORNO LEVA CAMBIO 250 2T IE | SPRING, RETURN GEAR LEVER 250 2S EI |
| 3 | 49073 | 1 | | RONDELLA 12,1X22X1 | WASHER 12,1X22X1 125 MF1/2 |
| 4 | 19060 | 1 | | ASTUCCIO A RULLI HK 1212 | NEEDLE CAGE HK 1212 |
| 5 | F26587 | 1 | | CRICCHETTO SX (HT) 250 M3 | RATCHET, LF GEAR (HT) 250 M3 |
| 6 | F26588 | 1 | | CRICCHETTO DX (HT) 250 M3 | RATCHET, RH GEAR (HT) 250 M3 |
| 7 | F26592 | 2 | | PUNTALE CRICCHETTO (HT) | PIN, RATCHET GEAR (HT) |
| 8 | F16469 | 2 | | MOLLA PER PUNTALE EDM | SPRING, GEARBOX PIN EDM |
| 9 | F26620 | 1 | | PORTACRICCHETTI HT 250MX | GEAR |
| 10 | 49482 | 2 | | VITE TCEI 6X14 UNI 5931 | BOLT TCEI 6X14 |
| 11 | 26160 | 1 | | PIASTRINO RIENTRO CRIC.250 M18 | PLATE |
| 12 | F49873 | 1 | | PERNO FILETTATO PER PORTACRICCHETTI (HT) | THREADED PIN FOR RATCHET HOLDER (HT) |
| 13 | F26589 | 1 | | TESTA ALBERO DESMODROMICO (HT) | CAM, HEAD |
| 14 | F19504 | 1 | | RULLO D.4 X 8 | PIN D.4 X 8 |
| 15 | F03381 | 1 | | CUSCINETTO 61805 | BUSH 61805 |
| 16 | F48352 | 1 | | PIASTRINO FISSA CUSCINETTO D72 | PLATE |
| 17 | 49403 | 1 | | VITE TSEI 6X12 ZINCATO | SCREW TSEI 6x12 |
| 18 | 33253 | 1 | | ALBERO DESM.250/300 INT. MY19 CPL | |
| 19 | 26260 | 1 | | BOCCOLA ALB. DESMODROMICO 250/300 2T I.E. | BUSH |
| 20 | 33260 | 1 | | PERNO FORCHETTA AP 250/300 MY19 | PIN, MAINSHAFT FORK |
| 21 | 33018 | 1 | | FORCHETTA ALB.PRIM.250/300 M18 4A E 5A | FORK, MAINSHAFT |
| 22 | F19533 | 3 | | RULLO D.6 X 15 | PIN |
| 23 | 33025 | 1 | | PERNO FORCHETTA AS 250/300 MY19 | PIN, COUNTERSHAFT FORKS |
| 24 | 33023 | 1 | | FORCHETTA A.S.1^3^ 250/300 M18 1A E 3A | FORK 1, COUNTERSHAFT |
| 25 | 33024 | 1 | | FORCHETTA A.S.2^ 250/300 M18 2A | FORK 2, COUNTERSHAFT |
| 26 | 43049 | 1 | | LEVA CAMBIO 2T (485) MY19-> | GEAR LEVER 250 / 300 T.STR. EL.ST. M.19-> |
| 27 | 04038 | 1 | | PARAOLIO LEVA CAMBIO 250/300 2T I 12x20x5 l.parapolv. | OIL SEAL GEAR LEVEL 250/300 2S Fi 12x20x5 |
| 28 | 49212 | 1 | | SEEGER E12 LEVA CAMBIO | CIRCLIP D.12 - EXTERNAL |



2T250MX23-M
MOTORE - ENGINE

FORCHETTE CAMBIO 5M

7

| Pos. | Codice | Q.tà | Note | Descrizione | Description |
|------|--------|------|------|--------------------------------|------------------------------|
| 29 | 49485 | 1 | | VITE TCEI 6X25 UNI 5931 | BOLT TCEI 6x25 |
| 30 | 26007 | 1 | | DISTANZIALE MOLLA BLOCCAMARCE | SPACER, STOP GEAR SPRING |
| 31 | F16447 | 1 | | MOLLA BLOCCA MARCE 250N | SPRING, STOP GEAR 250 4S |
| 32 | F26479 | 1 | | PIASTRINO BLOCCA MAR. 250Fi 12 | PLATE, STOP GEAR 250 4S 12-> |

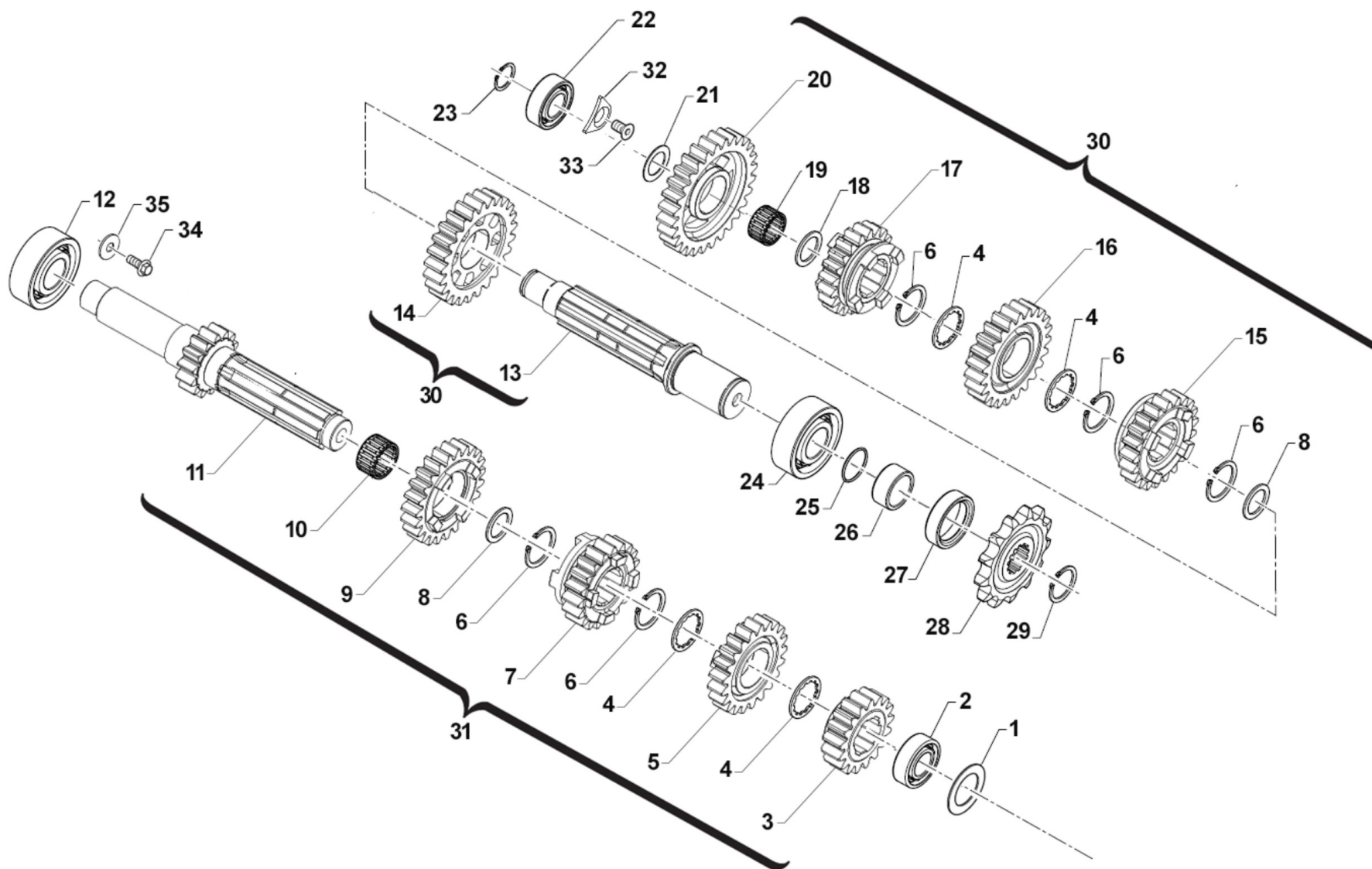



2T250MX23-M
MOTORE - ENGINE

CAMBIO 5M

8

| Pos. | Codice | Q.tà | Note | Descrizione | Description |
|------|-----------|------|------|--|---|
| 1 | F48401.30 | 1 | | RASAMENTO Ø20,3 x Ø35,9 x 0,30 | SHIM |
| 2 | F03379 | 1 | | CUSCINETTO 16004 C3 | BUSH 16004 C3 |
| 3 | 40255 | 1 | | INGRAN A.P. 2a Z 17 250 CR/E | GEAR, 2ND (17T) MAINSHAFT MX/E |
| 4 | 48251 | 4 | | SPESSORE DENT.CAMBIO 250/KZ10B | SPACER, GEAR 250cc |
| 5 | 40260 | 1 | | INGRAN A.P. 4a Z 21 250 CR/E | GEAR, 4TH (21T) MAINSHAFT MX/E |
| 6 | 49255 | 5 | | SEEGER RETTIFICATO CAMBIO 250 | CIRCLIP, GEAR BOX 250cc |
| 7 | 40258 | 1 | | INGRAN A.P. 3a Z 19 250 CR/E | GEAR, 3RD (19T) MAINSHAFT MX/E |
| 8 | 48254 | 2 | | SPES.RE CAMBIO 25.2X31.8X1 250 | SPACER,GEAR BOX250 25.2X31.8X1 |
| 9 | 40262 | 1 | | INGRAN A.P. 5a Z 23 250/CROSS | GEAR, 5TH (23T) MAINSHAFT MX |
| 10 | 19051 | 1 | | GABBIA ING. V AP. 250 | NEEDLE CAGE K 25x29x10 AP250 |
| 11 | 40254 | 1 | | ALBERO PRIMARIO CR Z15/250 M18 | MAINSHAFT 15 T |
| 12 | 03252 | 1 | | CUSCINETTO 6205 C4 A/P 250/K9 | BUSH, MAINSHAFT 250 / KZ |
| 13 | 40271 | 1 | | ALBERO SECONDARIO 250 M.2018 | COUNTERSHAFT |
| 14 | 40275 | 1 | | INGRAN A.S. 2a Z 25 250 CR/E | GEAR, 2ND(25T)COUNTER.MX/E 250 |
| 15 | 40279 | 1 | | INGRAN A.S. 4a Z 21 250 CR/E | GEAR, 4TH(21T)COUNTER.MX/E 250 |
| 16 | 40277 | 1 | | INGRAN A.S. 3a Z 23 250 CR/E | GEAR, 3RD(23T)COUNTER.MX/E 250 |
| 17 | 40281 | 1 | | INGRAN A.S. 5a Z 20 250/CROSS | GEAR, 5TH(20T)COUNTERSH.MX 250 |
| 18 | 48252 | 1 | | SPESSORE CAMBIO 20X29X1 250 | SPACER, GEAR 250 20X29X1 |
| 19 | 19012 | 1 | | GABBIA A RULLI K 20X24X10 | BUSH NEEDLE CAGE 20 X 24 X 10 |
| 20 | 40272 | 1 | | INGRAN A.S. 1a Z 27 250/CROSS | GEAR, 1ST(27T)COUNTERSH.MX 250 |
| 21 | 48059 | 1 | | Spessore alb.sec. 2T IE 17x28x3.5 | SPACER |
| 22 | 03251 | 1 | | CUSCINETTO 6203/C3 A/P A/S 250 | BUSH, MAINSHAFT COUNTER.250/4T |
| 23 | F49876 | 1 | | SEEGER E 17 X 1,5 CAMBIO 250/300 2T 19-> | CIRCLIP E 17 GEAR BOX 250/300 2S MY.19-> |
| 24 | 03020 | 1 | | CUSCINETTO RULLI NJ205ET2XC3 (BANCO 85/100 M.18) | BUSH CRANKSHAFT 85/100->18 NJ205ET2XC3 |
| 25 | 12252 | 1 | | O RING PIGNONE CAT.+DIS.AL.MOT | O-RING, 25,12 x 1,78 |
| 26 | 26261 | 1 | | DISTANZIALE PIGNONE CAT.250/300 2T 19 | SPACER SPROCKET DRIVE 250/300 T.S. MY19-> |
| 27 | 04101 | 1 | | PARAOLIO PIGNONE CATENA 250 | OIL SEAL 40 x 30 x 7 |
| 28 | 40212 | 1 | | PIGNONE CATENA Z12 250 | SPROCKET 12T, DRIVE 250/300/4T |



2T250MX23-M
MOTORE - ENGINE

CAMBIO 5M

8

| Pos. | Codice | Q.tà | Note | Descrizione | Description |
|------|--------|------|------|--|------------------------------------|
| 28 | 40214 | 1 | | PIGNONE CATENA Z13 250/2T e 4T | SPROCKET 13T, DRIVE 250/300/4T |
| 29 | 49252 | 1 | | SEEGER PIGNONE CATENA 250 E 25 | CIRCLIP D.25 FRONT SPROKET 250 |
| 30 | 40294 | 1 | | ALBERO PRIMARIO MX CPL 250/300 2T ES MY 2019 | MAINSHAFT 250/300 2S MX ES ASSY |
| 31 | 40295 | 1 | | ALBERO SECONDARIO MX CPL 250/300 2T ES MY 2019 | COUNTERSHAFT 250/300 2S MX ES ASSY |
| 32 | F48352 | 1 | | PIASTRINO FISSA CUSCINETTO D72 | PLATE |
| 33 | 49403 | 1 | | VITE TSEI 6X12 ZINCATO | SCREW TSEI 6x12 |
| 34 | 49962 | 1 | | VITE TCEI 6X12 BASSA / F.GUIDA | BOLT |
| 35 | 49603 | 1 | | RONDELLA M 6,4 X 12 X 1,6 | WASHER 6x12 |

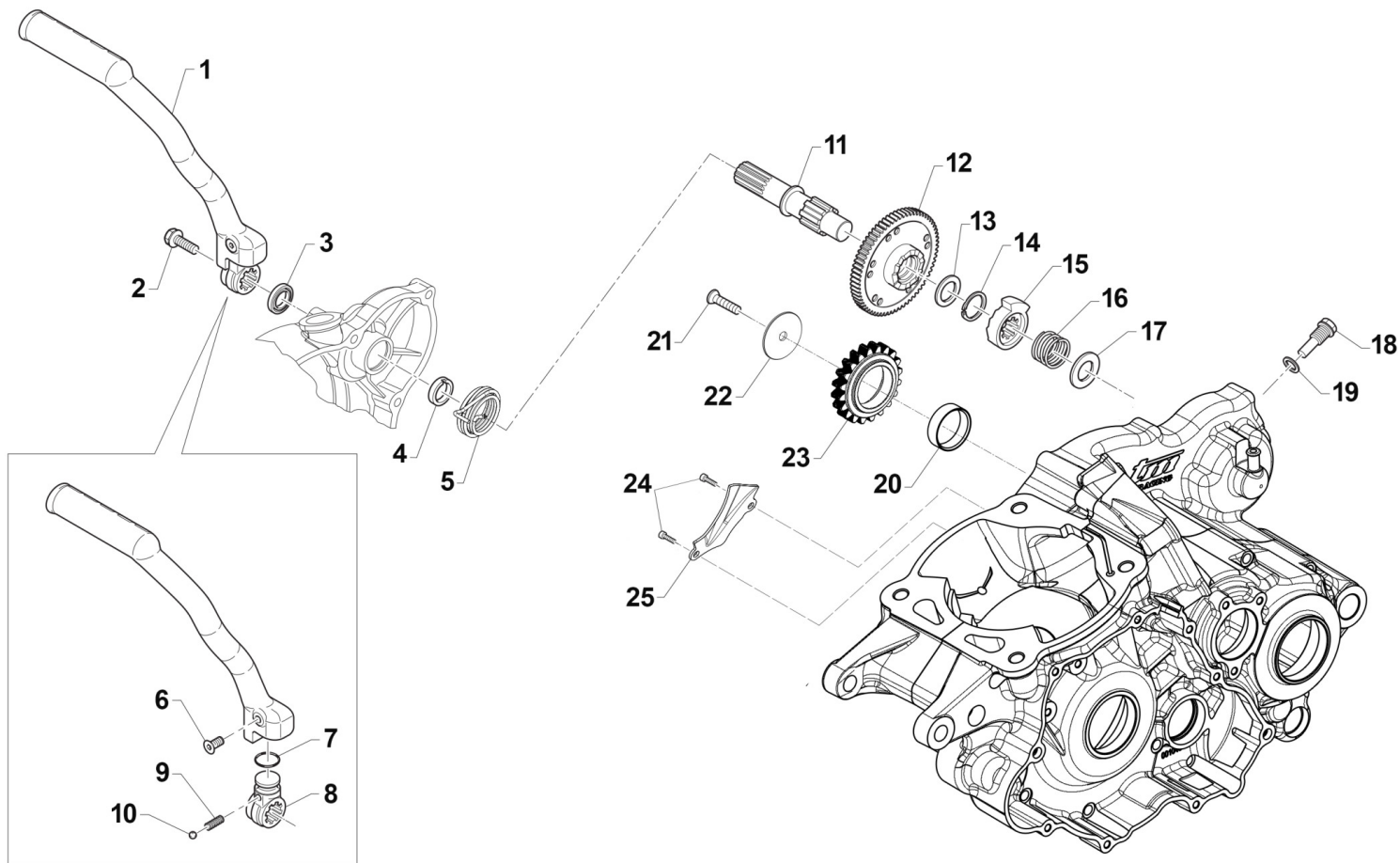



2T250MX23-M
MOTORE - ENGINE

MESSA IN MOTO
KICK STARTER

| Pos. | Codice | Q.tà | Note | Descrizione | Description |
|------|----------|------|------|---|--------------------------------|
| 1 | 43250.19 | 1 | | LEVA M/M 250/300 2T ES MY 2019 | LEVER, KICK STARTER |
| 2 | 49369 | 1 | | VITE TE F/R 8X10 Ch.10 M/M | BOLT 8X10 T.10mm(Kich Starter) |
| 3 | F04365 | 1 | | PARAOLIO LEVA M/M 250/09 | OIL SEAL 18x28x6,5 KS LEVER |
| 4 | F26423 | 1 | | BOCCOLA MOLLA M/M. 250Fi | BUSH |
| 5 | F16428 | 1 | | MOLLA RICHIAMO AVVIAMENTO A P. | SPRING, KICK STARTER RETURN 4S |
| 6 | 49414 | 1 | | VITE TSPEI 6X30 NORMALE UNI 5933 | BOLT TSEI 6X30 |
| 7 | 12260 | 1 | | O RING INTERNO LEVA M/M 250 | O-RING INT.LEVER KICK START250 |
| 8 | F43376 | 1 | | MOZZETTO KICK START CORTO 2T (+ 250/300 4T) | BLOCK, KICK STARTER 250N 08-> |
| 9 | 16039 | 1 | | MOLLA X SFERA LEVA M/M 250 CC | SPRING, BALL KICK-START. 250cc |
| 10 | 43250.03 | 1 | | SFERA 1/4C X LEVA M/M 250 CC | BALL, KICK STARTER LEVER 250cc |
| 11 | F28657 | 1 | | ALBERO M/M 250Fi | SHAFT, KICK STARTER |
| 12 | 40346 | 1 | | INGR. CONDUTTORE M/M 250/300 | GEAR |
| 13 | F48355 | 1 | | SPESSORE TT 18 X 23 X 0,5 | SHIM 18 X 23 X 0,5 |
| 14 | F49835 | 1 | | SEEGER AV 18 | SEEGER |
| 15 | F26424 | 1 | | BUSSOLA A CRICC.X K.S. 250N | K.STARTER STOPPER CAM 250 4S |
| 16 | F16429 | 1 | | MOLLA CRICCHETTO AVV.A PEDALE | SPRING |
| 17 | F48354 | 1 | | SPESSORE TT 14 X 30 X 0,5 | SPACER |
| 18 | 49987 | 1 | | VITE DISIMP.CRICCH.M/M.250/300 2T ES MY 2019 | BOLT |
| 19 | F49939 | 1 | | RONDELLA RAME 8 X13 X 1,5 | WASHER COPPER 8,5X13X1,5 |
| 20 | 26262 | 1 | | BRONZINA ING. FOLLE M/M RINF. 250/300 2T | BUSH |
| 21 | 49440 | 1 | | VITE TE 6X14 | BOLT TE 6X14 |
| 22 | 49981 | 1 | | RONDELLA 6x31x1.5 x ING.FOLLE RINF. 250/300 2T 2019 | WASHER |
| 23 | 40362 | 1 | | INGRANAGGIO FOLLE M/M RINF. 250/300 | GEAR |
| 24 | 49580 | 2 | | VITE TCEI 4X10 5931-912 Brun | BOLT |
| 25 | 26162 | 1 | | PIASTRINO CONV.OLIO 250/300 18 | PLATE |

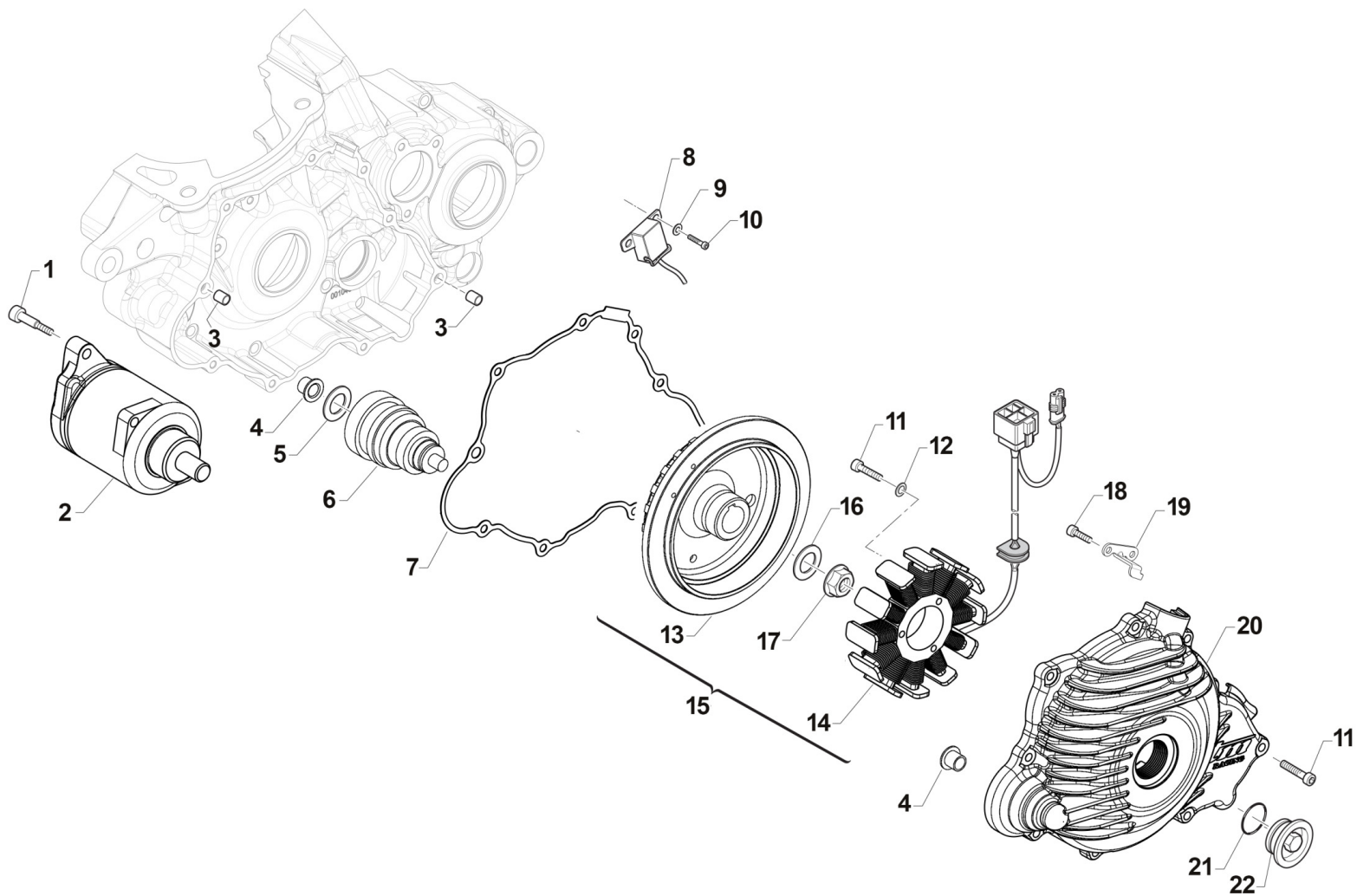



2T250MX23-M
MOTORE - ENGINE

ACCENSIONE
IGNITION

10

| Pos. | Codice | Q.tà | Note | Descrizione | Description |
|------|----------|------|------|---|--|
| 1 | 49485 | 2 | | VITE TCEI 6X25 UNI 5931 | BOLT TCEI 6x25 |
| 2 | 68206 | 1 | | MOTORINO AVVIAMENTO 250/300 M18-> | STARTER MOTOR 250/300 T.S. MY19-> |
| 3 | 26041 | 2 | | GRANO CENTRAGGIO D.7X8 F.5,2 | DOWEL PIN 7 x 8 Hole 5,2 |
| 4 | 26256 | 2 | | BOCCOLA FLANGIATA BENDIX AVV. EL. 250/300 2T I.E. | FLANGE BUSH BENDIX EL.ST. 250/300 T.S. Fi |
| 5 | 72418.23 | 1 | | LAMELLA D.8 23-020 | |
| 6 | 68207 | 1 | | BENDIX MOTORE 250/300 2T ES MY 2019 | BENDIX |
| 7 | 05260 | 1 | | GUARN. COP. ACC. 250/300 2T ES M19-> | GASKET, IGNITION COVER 250/300 2S ES MY 19 |
| 8 | F15478 | 1 | | PICK-UP KOKUSAN | PICK-UP KOK PU5157 |
| 9 | 49601 | 2 | | RONDELLA 5X11 | WASHER 5x11 |
| 10 | 49472 | 2 | | VITE TCEI 5X12 UNI 5931-912 Brun | BOLT TCEI 5X12 |
| 11 | 49477 | 12 | | VITE TCEI 5X25 UNI 5931-912 | BOLT TCEI 5X25 |
| 12 | 49615 | 3 | | RONDELLA ACCIAIO 5x11x0,5 | WASHER STEEL 5 mm |
| 13 | 15247 | 1 | | ROTORE X GEN. ES 250/300 2T IE CPL M.19-> in C45 | ROTOR, INGNITION 250/300 2T ES MY 2019 |
| 13 | F50816 | 1 | | ESTRATTORE ACC KOK 125Fi + 250/300 2T ES 19-> | FLYWHEEL PULLER KOKUSAN 250/300 2S MY.19-> |
| 14 | F15551 | 1 | | STATORE KOKUSAN YS 9022 | STATOR KOKUSAN YS 9022 |
| 15 | 15255 | 1 | | ACCENSIONE CPL 250/300 2T ES MY 201915247 + F15551 | IGNITION ASSY 250/300 T.S. ES MY 19-> |
| 16 | 49613 | 1 | | RONDELLA ACCIAIO 12 | STEEL WASHER 12 |
| 17 | 49056 | 1 | | DADO ACCENS 100/TAG/KZ 125MX/E | NUT, IGNITION 100cc |
| 18 | 49580 | 2 | | VITE TCEI 4X10 5931-912 Brun | BOLT |
| 19 | F30945 | 1 | | PROTEZIONE CAVI ACC.NE 250N | PROTECTION IGNITION WIRES 250N |
| 20 | 30278 | 1 | | COPERCHIO ACCENSIONE 250/300 2T ES MY 19 | IGNITION COVER 250/300 2S E.S. MY19-> |
| 21 | F12322 | 1 | | O RING 2106 | O-RING |
| 22 | 49290 | 1 | | TAPPO COPERCHIO ACC. 250/300 2T MY 2019(PUO' SOSTITUIRE F49833) | CAP IGNITION COVER 250/300 2S MY19 |